

Product Specification

10Gb/s 1310nm Multimode Datacom XFP Transceiver

☑ Features:

- Hot pluggable
- Support 9.95Gb/s to 11.1Gb/s bit rates
- Below 2W power dissipation
- XFP MSA package with duplex LC connector
- Digital Diagnostic Monitor Interface
- Very low EMI and excellent ESD protection
- Wavelength selectable to ITU-T standards covering CWDM grid wavelengths
- Up to 10KM for single mode fiber
- Operating temperature range -40°C to 85°C
- No reference clock requirement



☑ Applications:

- 10G BASE-LR/10G Ethernet

☑ Standard:

- XFP MSA compliant
- IEEE802.3ae-2002 compliant
- ITU-T G.959 and G.691 compliant
- GR-253-CORE compliant
- RoHS compliant

☑ Description:

- WT-XFP-LR 10G CWDM XFP transceivers are designed for 10G CWDM networks and High-speed storage area networks , and it can support data-rate from 9.953Gb/s to 11.1Gb/s. Digital diagnostics are available via I2C interface as specified in the XFP MSA.
- The transceiver designs are optimized for high performance and cost effective to supply customers the best solutions for datacom and telecom applications.

Shenzhen **Wintop** Optical Technology Co., Ltd.

Address: 6/f, Bldg. 1, Sec. 3, South area, Honghualing Industrial
Zone Xili Town, Nanshan District, Shenzhen China
Web: www.wintoptec.com

Tel: +86 - 755- 2664 1737
Fax: +86- 755- 2664 0197
Email: sales@wintoptec.com

☑ Functional Diagram:

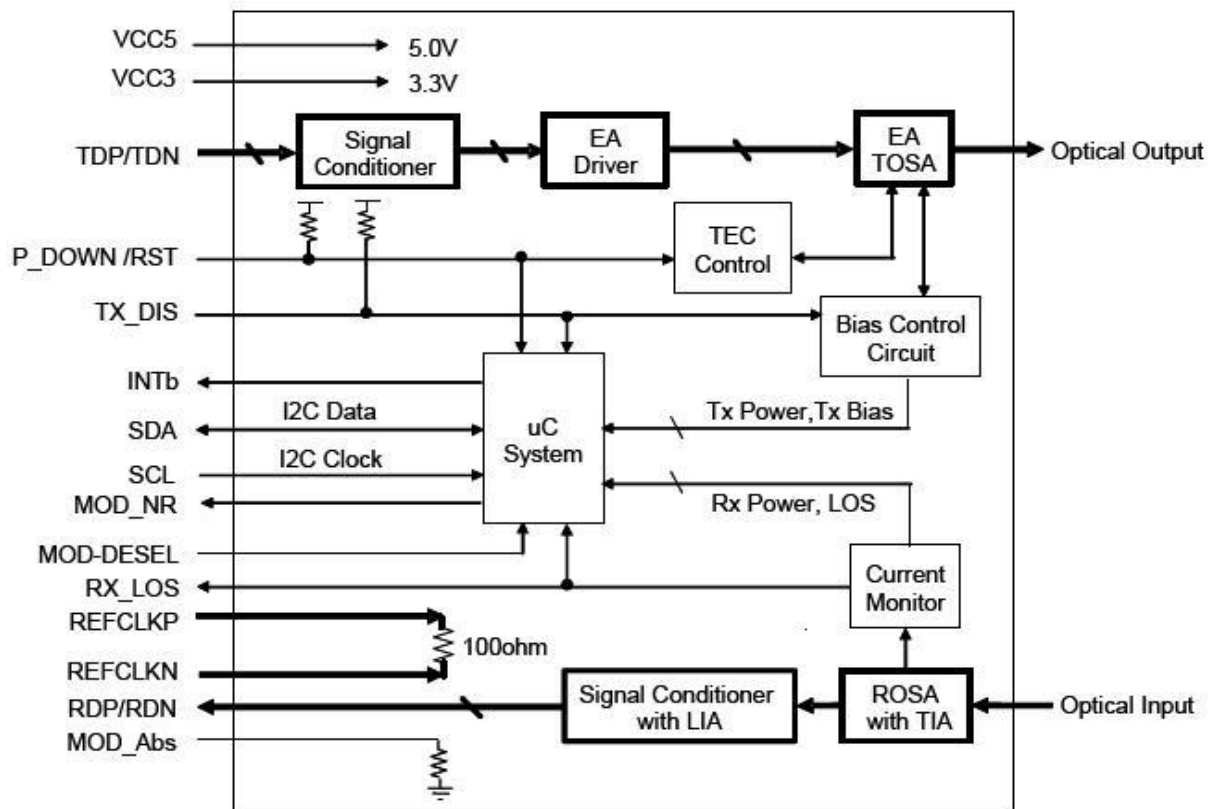

Shenzhen **Wintop** Optical Technology Co., Ltd.

Address: 6/f, Bldg. 1, Sec. 3, South area, Honghualing Industrial
Zone Xili Town, Nanshan District, Shenzhen China
Web: www.wintoptec.com

Tel: +86 - 755- 2664 1737
Fax: +86- 755- 2664 0197
Email: sales@wintoptec.com

☑ Pin Definitions:

Pin	Logic	Symbol	Name/Description	Note
1		GND	Module Ground	1
2		VEE5	Optional -5.2V Power Supply	
3	LVTTTL-I	MOD_DESEL	Module De-select; When held low allows the module to respond to 2-wire serial interface	
4	LVTTTL-O	/INTERRUPT	Interrupt; Indicates presence of an important condition which can be read via the 2-wire serial interface	2
5	LVTTTL-I	TX_DIS	Transmitter Disable; Turns off transmitter laser output	
6		VCC5	+5V Power Supply	
7		GND	Module Ground	1
8		VCC3	+3.3V Power Supply	
9		VCC3	+3.3V Power Supply	
10	LVTTTL-I/O	SCL	2-Wire Serial Interface Clock	2
11	LVTTTL-I/O	SDA	2-Wire Serial Interface Data Line	2
12	LVTTTL-O	MOD_Abs	Indicates Module is not present. Grounded in the Module	2
13	LVTTTL-O	MOD_NR	Module Not Ready; Indicating Module Operational Fault	2
14	LVTTTL-O	RX_LOS	Receiver Loss Of Signal Indicator	2
15		GND	Module Ground	1
16		GND	Module Ground	1
17	CML-O	RD-	Receiver Inverted Data Output	
18	CML-O	RD+	Receiver Non-Inverted Data Output	
19		GND	Module Ground	1
20		VCC2	+1.8V Power Supply (Not required).	3
21	LVTTTL-I	P_DOWN/RST	Power down; When high, requires the module to limit power consumption to 1.5W or below. 2-Wire serial interface must be functional in the low power mode.	
			Reset; The falling edge initiates a complete reset of the module including the 2-wire serial interface, equivalent to a power cycle.	
22		V _{CC2}	+1.8V Power Supply (Not required)	3
23		GND	Module Ground	1
24	PECL-I	REFCLK+	Not used, internally terminated to 50ohm (100ohm diff).	4
25	PECL-I	REFCLK-	Not used, internally terminated to 50ohm (100ohm diff).	4
26		GND	Module Ground	1
27		GND	Module Ground	1
28	CML-I	TD-	Transmitter Inverted Data Input	
29	CML-I	TD+	Transmitter Non-Inverted Data Input	
30		GND	Module Ground	1

1. Module ground pins GND are isolated from the module case and chassis ground within the module.
2. Open collector; Shall be pulled up with 4.7K-10Kohms to a voltage between 3.15V and 3.6V on the host board.
3. The pins are open within module.
4. Reference Clock is not required.

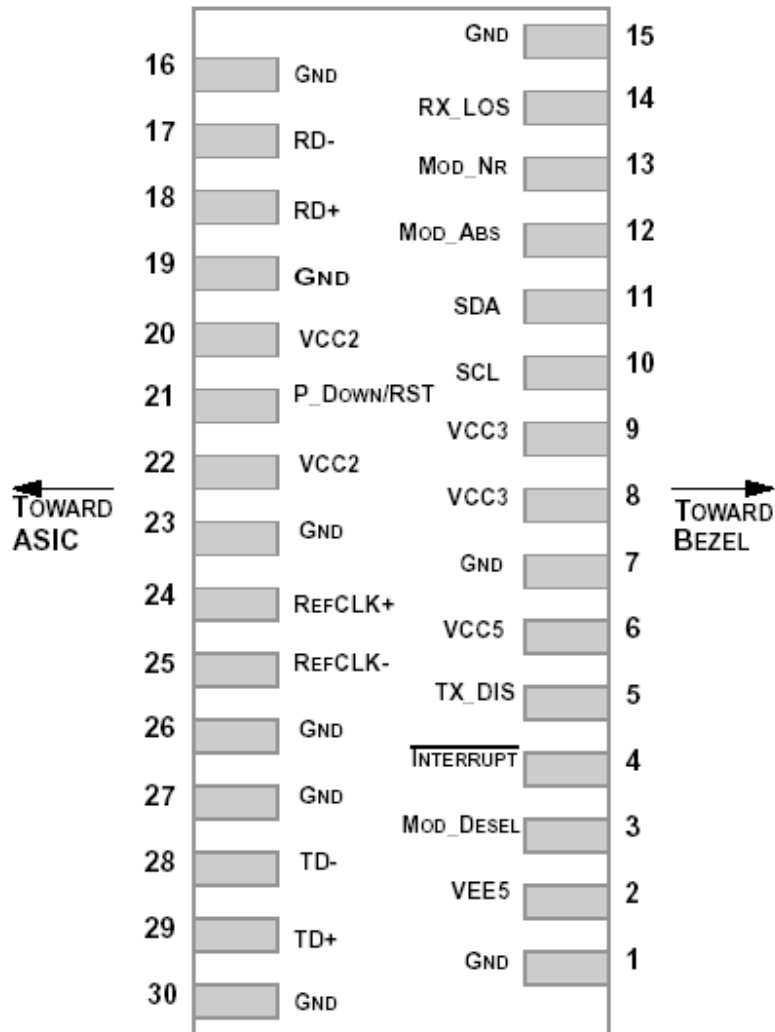

☑ Absolute Maximum Ratings:

Parameter	Symbol	Min.	Max.	Unit
Storage Temperature	T_s	-40	+85	°C
Power Supply Voltage	V_{CC3}	-0.5	4.0	V
	V_{CC5}	-0.5	6.0	
Operating Relative Humidity	RH		85	%

☑ Electrical Characteristics:

Parameter	Symbol	Min.	Typical	Max.	Unit	Notes
Operating Case Temperature	T_c	-40		+85	°C	
Power Supply Voltage	V_{CC3}	3.13	3.3	3.47	V	
	V_{CC5}	4.75	5.0	5.25	V	
Power Supply Current	I_{CC3}			600	mA	1
	I_{CC5}			100	mA	1
Power Dissipation	P_D			3.5	W	1
Power Supply Noise Rejection	PSNR					2
Transmitter						
Input Differential Impedance	R_{input}		100		Ω	3
Differential Data Input Swing	$V_{in,pp}$	120		820	mV	
TX_DIS Voltage	V_{TX_DIS}	2.0		V_{CC3}	V	4
TX_EN Voltage	V_{TX_EN}	0		0.8	V	
TX_DIS Assert Time				10	us	
TX_DIS Deassert Time				2	ms	
Receiver						
Differential Data Output Swing	$V_{out,pp}$	500	650	800	mV	5
Data output Rise/Fall Time(20%~80%)	t_r / t_f			45	ps	

Note:

1. Maximum total power value is specified across the full temperature and voltage range and the inrush current is included
2. Per section 2.7.1 in the XFP MSA specification
3. After internal AC coupling
4. Or open collector
5. Into 100 Ω termination

Shenzhen **Wintop** Optical Technology Co., Ltd.

Address: 6/f, Bldg. 1, Sec. 3, South area, Honghualing Industrial
Zone Xili Town, Nanshan District, Shenzhen China
Web: www.wintoptec.com

Tel: +86 - 755- 2664 1737
Fax: +86- 755- 2664 0197
Email: sales@wintoptec.com

☑ Optical Characteristics:

Transmitter (-40~85°C @9.953Gb/s~11.1Gb/s)						
Parameter	Symbol	Min.	Typ.	Max.	Unit	Note
Operating Date Rate		9.95		11.1	Gb/s	
Ave. Output Power	Po	-3		0	dBm	1
Output Centre Wavelength	λ	1464.5		1617.5	nm	
Disable Power	Poff			-30	dBm	
Extinction Ratio	ER	8.2			dB	1
Sidemode Supression Ratio		30			dB	
Rise/Fall Time (20%~80%)	Tr/Tf			45	ps	
Dispersion penalty				2	dB	1
Generation Jitter 1(20KHZ-80MHZ)				0.3	Ulp-p	1
Generation Jitter 2(4MHZ-80MHZ)				0.1	Ulp-p	1
Optical Eye Mask 1		GR-253-CORE/ITU-T G.691				1
Optical Eye Mask 2		IEEE802.3ae				2
Receiver (-40~85°C @9.953Gb/s~11.1Gb/s)						
Parameter	Symbol	Min.	Typ.	Max.	Unit	Note
Operating Date Rate		9.95		11.1	Gb/s	
Overload	Po	0.5			dBm	
Input Centre Wavelength	λ	1260		1620	nm	
Receiver Sensitivity	Pmin			-16	dBm	1
Stressed Sensitivity in OMA				-11.3	dBm	2
LOS Assert	LosA	-30			dBm	
LOS De-assert	LosD			-18	dBm	
LOS Hysteresis		0.5		4	dB	
Optical Return Loss		14			dB	
Jitter Tolerance		GR-253-CORE/ITU-T G.783				1

Note :

1. Measured at 9.95328Gb/s,Framed PRBS2³¹-1,NRZ
2. Measured at 10.3125Gb/s,Non-framed PRBS2³¹-1,NRZ

☑ Management Interface:

XFP 2-wire serial interface is specified in the Chapter 4 of the XFP MSA specification. The XFP 2-wire serial interface is used for serial ID, digital diagnostics, and certain control functions. The 2-wire serial interface is mandatory for all XFP modules. The 2-wire serial interface address of the XFP module is 1010000X(A0h). In order to access to multiple modules on the same 2-wire serial bus, the XFP has a MOD_DESEL(module deselect pin). This pin (which is pull high or deselected in the module) must be held low by the host to select of interest and allow communication over 2-wire serial interface. The module must not respond to or accept 2-wire serial bus instructions unless it is selected.

☑ XFP Management Interface:

XFP Management interface is specified in the Chapter 5 of the XFP MSA specification. The Figure 1 shows the structure of the memory map. The normal 256 Byte address space is divided into lower and upper blocks of 128 Bytes. The lower block of 128 Byte is always directly available and is used for the diagnostics and control functions that must be accessed repeatedly. Multiple blocks of memories are available in the upper 128 Bytes of the address space. These are individually addressed through a table select Byte which the user enters into a location in the lower address space. The upper address space tables are used for less frequently accessed functions and control space for future standards definition.

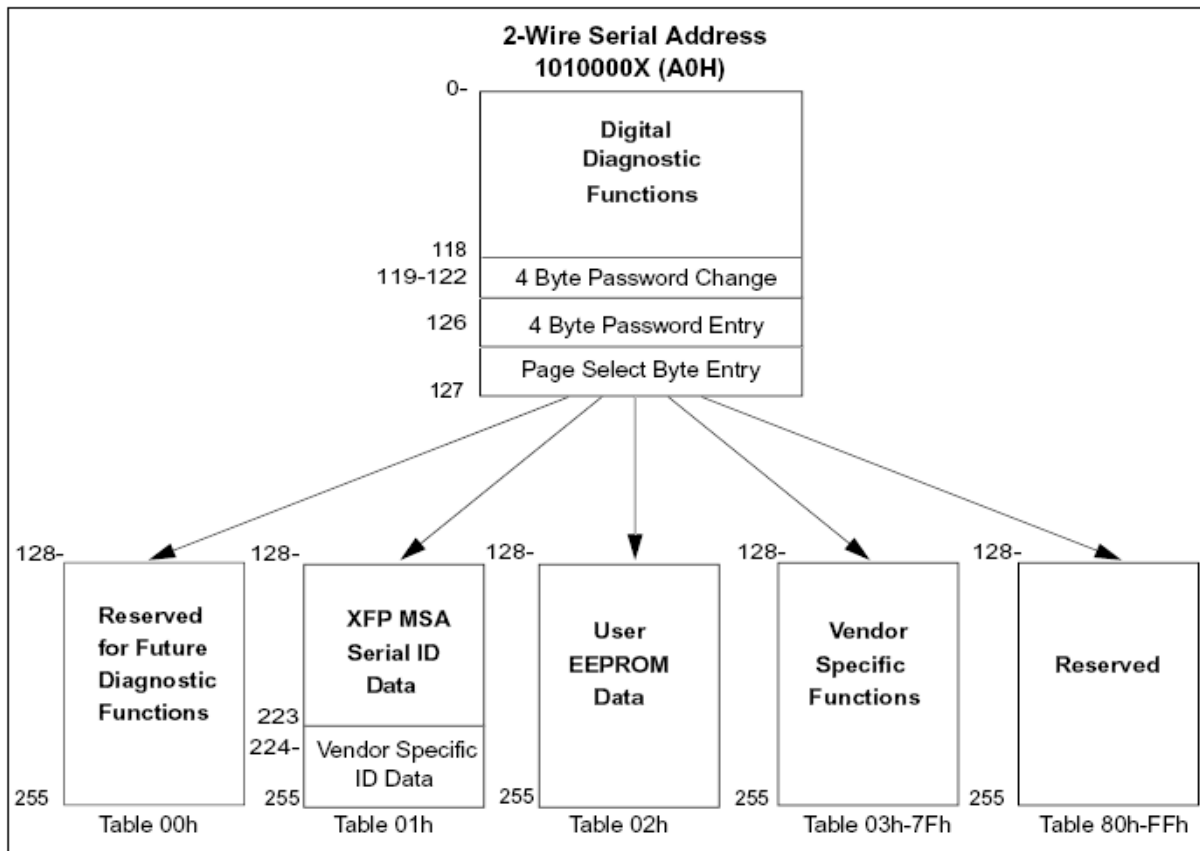

Figure 1 :2-wire Serial Interface Memory Map

Shenzhen *Wintop* Optical Technology Co., Ltd.

Address: 6/f, Bldg. 1, Sec. 3, South area, Honghualing Industrial
Zone Xili Town, Nanshan District, Shenzhen China
Web: www.wintoptec.com

Tel: +86 - 755- 2664 1737
Fax: +86- 755- 2664 0197
Email: sales@wintoptec.com

Serial ID Memory Contents (Table 01h):

Data Address	Size (Bytes)	Name of Field	Value (Hex)	Description
128	1	Identifier	06	XFP
129	1	Ext. Identifier	90	TX Ref Clock Input not Required
130	1	Connector	07	LC Connector
131-138	8	Transceiver	22 00 00 00 20 00 00 00	10GBASE-ER/EW,S-64.2b
139	1	Encoding	B0	64B/66B SONET scrambled NRZ
140	1	BR-Min	63	9.953Gbps
141	1	BR-Max	6F	11.1Gbps
142	1	Length (SMF)-km	28	40km
143	1	Length (E-50um)	00	
144	1	Length(50um)	00	
145	1	Length(62.5um)	00	
146	1	Length (Copper)	00	
147	1	Device Tech	74	1550nm EML,PIN Detector
148-163	16	Vendor name		
164	1	CDR Support	F8	CDR supports 9.953Gbps~11.1Gbps
165-167	3	Vendor OUI	00 00 00	
168-183	16	Vendor PN		
184-185	2	Vendor rev	xx xx	ASC II (;31 62; means 1b revision)
186-187	2	Wavelength	79 18	Wavelength
188-189	2	Wavelength Tolerance	0F A0	+/- 6.5nm
190	1	Max Case Temp	46	70degC
191	1	CC_BASE		Check sum of bytes 128 - 190
192-195	4	Power Supply	AF 96 A7 01	3.5W(max),i j .
196-211	16	Vendor SN	xxxxxxxxxxxxxxxx	ASC II .
212-219	8	Data code	xxxxxxxxxxx 20 20	Year(2bytes),Month(2bytes),Day(2 bytes)
220	1	Diagnostic Monitoring Type	08	No BER Support,Average Power
221	1	Enhanced Options	60	Optional Soft Tx_Disable and P_Down
222	1	Aux Monitoring	67	+3.3V/5V Supply Voltage
223	1	CC_EXT	xx	Check sum of bytes 192 - 222
224-255	32	Vendor Specific		Vendor Specific EEPROM

☑ Typical Interface Circuit:

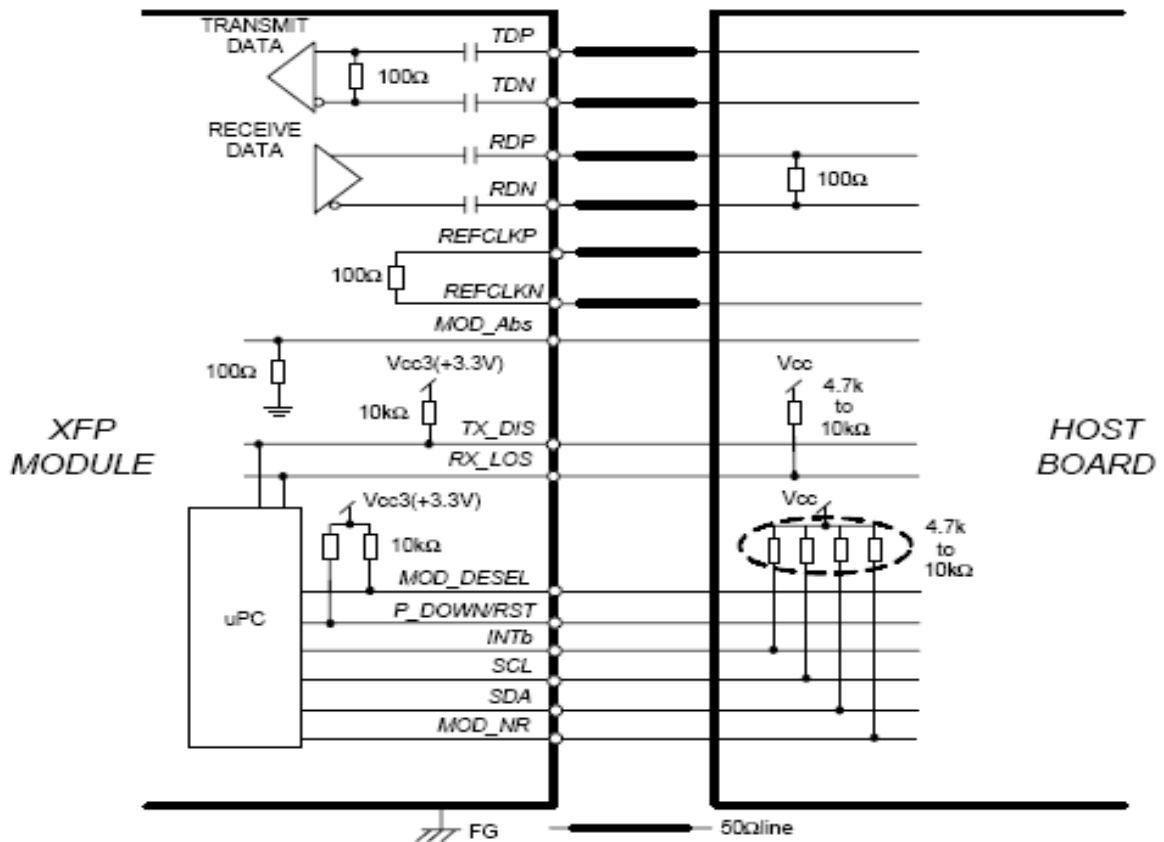

☑ Package Dimensions:

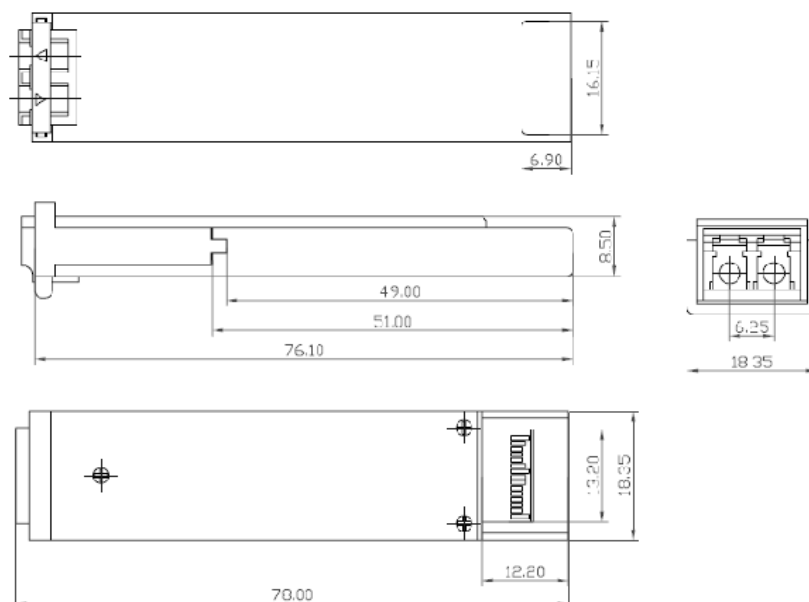

Shenzhen **Wintop** Optical Technology Co., Ltd.

Address: 6/f, Bldg. 1, Sec. 3, South area, Honghualing Industrial Zone Xili Town, Nanshan District, Shenzhen China
 Web: www.wintoptec.com

Tel: +86-755-2664 1737
 Fax: +86-755-2664 0197
 Email: sales@wintoptec.com