



10/100/1000M Media Converter – Technical Specification



1. Introduction

10/100/1000M adaptive fast Ethernet optical Media Converter is a new product used for optical transmission via high-speed Ethernet. It is capable of switching between twisted pair and optical and relaying across 10/100 Base-TX/1000 Base-Fx and 1000Base-FX network segments, meeting long-distance, high-speed and high-broadband fast Ethernet workgroup users' needs, achieving high-speed remote interconnection for up to 100 km's relay-free computer data network. With steady and reliable performance, design in accordance with Ethernet standard and lightning protection, it is particularly applicable to a wide range of fields requiring a variety of broadband data network and high-reliability data transmission or dedicated IP data transfer network, such as telecommunication, cable television, railway, military, finance and securities, customs, civil aviation, shipping, power, water conservancy and oilfield etc, and is an ideal type of facility to build broadband campus network, cable TV and intelligent broadband FTTB/FTTH networks.

2. Overview

2.1 Features

- In accordance with Ethernet standards IEEE802.3, 10/100Base-TX/1000Base-TX and 1000Base-FX



- Supported Ports: SC for optical fiber; RJ45 for twisted pair
- Auto-adaptation rate and full/half-duplex mode supported at twisted pair port
- Auto-negotiation and speed autosensing
- Auto MDI/MDIX supported without need of cable selection
- Up to 6 LEDs for status indication of optical power port and UTP port
- External and built-in DC power supplies provided
- Up to 1024 MAC addresses supported
- 512 kb data storage integrated, and 802.1X original MAC address authentication supported
- Conflicting frames detection in half-duplex and flow control in full duplex supported

2.2 Technical Parameters

Technical Parameters for 10/100/1000M Adaptive Fast Ethernet Optical Media Converter	
Number of Network Ports	1 channel
Number of Optical Ports	1 channel
NIC Transmission Rate	10/100/1000Mbit/s
NIC Transmission Mode	10/100/1000M adaptive with support for automatic inversion of MDI/MDIX
Optical Port Transmission Rate	1000Mbit/s
Operating Voltage	AC 220V or DC +5V
Overall Power	<3W
Network Ports	RJ45 port
Optical Specifications	Optical Port: SC, FC,ST (Optional) Multi-Mode: 50/125, 62.5/125um Single-Mode: 8.3/125, 8.7/125um, 8/125,10/125um Wavelength: Single-Mode: 1310/1550nm
Data Channel	IEEE802.3x and collision base backpressure supported Working Mode: Full/half duplex supported Transmission Rate: 1000Mbit/s with error rate of zero





Some Product Modes and port Technical Parameters of Optical Port						
Desk Type Dual-Optical Single-Mode/Multi-Mode Media Converter						
Product Mode	Wavelength (nm)	Optical Port	Electric Port	Optical Power (dBm)	Receiving Sensitivity (dBm)	Transmission Range (km)
YT-8110GMA-11-05-AS	850nm	SC	RJ-45	-8~-3	≤-19	0.55km
YT-8110GMA-11-2-AS	1310nm	SC	RJ-45	-8~-3	≤-20	2km
YT-8110GSA-11-10-AS	1310nm	SC	RJ-45	-8~-3	≤-24	10km
YT-8110GSA-11-20-AS	1310 nm	SC	RJ-45	-8~-3	≤-24	20km
YT-8110GSA-11-40-AS	1310 nm	SC	RJ-45	-5~0	≤-24	40km
YT-8110GSA-11-60-AS	1310 nm	SC	RJ-45	-2~+3	≤-24	60km
YT-8110GSA-11-80-AS	1550 nm	SC	RJ-45	0~5	≤-24	80km
YT-8110GSA-11-100-AS	1550 nm	SC	RJ-45	0~5	≤-30	100km
Desk Type Single-Optical Two-Way Media Converter						
Product Mode	Wavelength (nm)	Optical Port	Electric Port	Optical Power (dBm)	Receiving Sensitivity (dBm)	Transmission Range (km)
YT-8110GSB-11-05A-AS	1310nm	SC	RJ-45	-8~-3	≤-24	0.55km
YT-8110GSB-11-05B-AS	1550nm	SC	RJ-45	-8~-3	≤-24	0.55km
YT-8110GSB-11-10A-AS	1310 nm	SC	RJ-45	-8~-3	≤-24	10 km
YT-8110GSB-11-10B-AS	1550 nm	SC	RJ-45	-8~-3	≤-24	10 km
YT-8110GSB-11-20A-AS	1310 nm	SC	RJ-45	-8~-3	≤-24	20 km
YT-8110GSB-11-20B-AS	1550 nm	SC	RJ-45	-8~-3	≤-24	20 km
YT-8110GSB-11-40A-AS	1310 nm	SC	RJ-45	-5~0	≤-24	40 km
YT-8110GSB-11-40B-AS	1550 nm	SC	RJ-45	-5~0	≤-24	40 km
YT-8110GSB-11-60A-AS	1490 nm	SC	RJ-45	-5~0	≤-24	60 km
YT-8110GSB-11-60B-AS	1550 nm	SC	RJ-45	-5~0	≤-24	60 km
YT-8110GSB-11-80A-AS	1490 nm	SC	RJ-45	0~5	≤-24	80 km
YT-8110GSB-11-80B-AS	1550 nm	SC	RJ-45	0~5	≤-24	80 km

3. Operating Environment

3.1 Operating Voltage

AC 220V/ DC +5V

3.2 Operating Humidity

Operating Temperature: 0°C to +55°C

Storage Temperature: -20°C to +70°C



Humidity: 5% to 90%

4. Quality Assurance

MTBF > 100,000 hours;

Replacement within one year and non-charge repair within three years guaranteed

5. Application Fields

- For intranet prepared for expansion from 100M to 1000M
- For integrated data network for multimedia such as image, voice and etc.
- For point-to-point computer data transmission
- For computer data transmission network in a wide range of business application
- For broadband campus network, cable TV and intelligent FTTB/FTTH data tape
- In combination with switchboard or other computer network facilitates for: chain-type, star-type and ring-type network and other computer networks

6. Remarks and Notes

6.1 Instructions on Media Converter Panel

Instructions on Front Panel

Identification for front panel of the media converter is shown below:

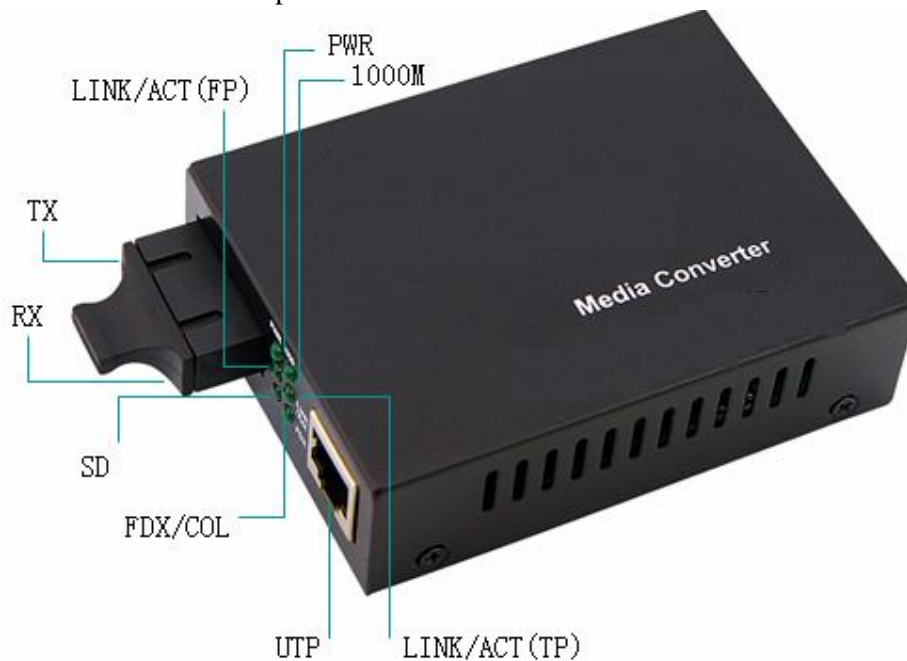



a. Identification of Media Converter

TX - transmitting terminal; RX - receiving terminal;

b. PWR

Power Indicator Light – “ON” means normal operation of DC 5V power supply adaptor.

c. 1000M Indicator Light

“ON” means the rate of the electric port is 1000 Mbps, while “OFF” means the rate is 100 Mbps.

d. LINK/ACT (FP)

“ON” means connectivity of the optical channel; “FLASH” means data transfer in the channel; “OFF” means non-connectivity of the optical channel.

e. LINK/ACT (TP)

“ON” means connectivity of the electric circuit; “FLASH” means data transfer in the circuit; “OFF” means non-connectivity of the electric circuit.

f. SD Indicator Light

“ON” means input of optical signal; “OFF” means non input.

g. FDX/COL:

“ON” means full duplex electric port; “OFF” means half-duplex electric port.

h. UTP

Non-shielded twisted pair port;

Instructions on Rear Panel

There is only a DC 5V external power port on the rear panel:





6.2. Mounting Dimensions Sketch

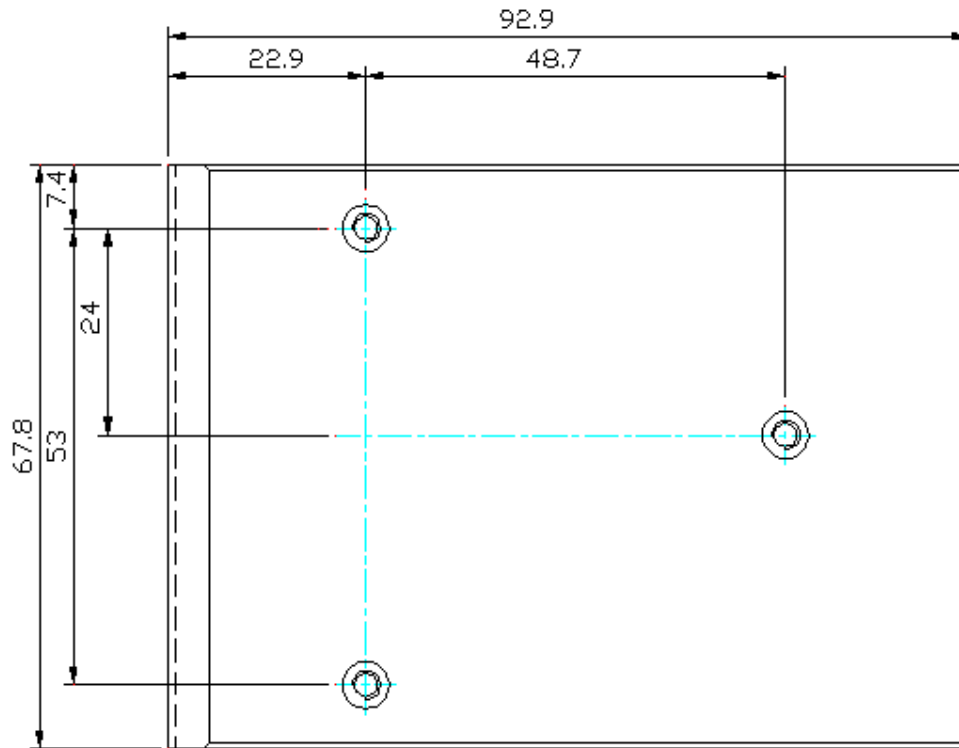

6.3. Product Connection Diagram

